

# **IntelliStripe 320**

## **MOTORIZED READER**

### **TECHNICAL REFERENCE MANUAL**

**Manual Part Number: 99875167 Rev 11**

**JUNE 2004**

**MAGTEK<sup>®</sup>**

**REGISTERED TO ISO 9001:2000**

20725 South Annalee Avenue

Carson, CA 90746

Phone: (310) 631-8602

FAX: (310) 631-3956

Technical Support: (651) 415-6800

[www.magtek.com](http://www.magtek.com)

Information in this document is subject to change without notice. No part of this document may be reproduced or transmitted in any form or by any means, electronic or mechanical, for any purpose, without the express written permission of MagTek, Inc.

MagTek is a registered trademark of MagTek, Inc.

IntelliStripe is a registered trademark of MagTek, Inc.

### REVISIONS

Rev Number	Date	Notes
1	12 May 00	Initial Release
2	23 Aug 00	Section 1, Added Front Gate caution; all U.S. dimensions, weights, and temp listed first and metric last and in ( ), editorial. Sec 3, Fig 3-1, Changed capacitor wire from 5.1672 in to 79 in.
3	18 Oct 00	Sec 1: Electrical Spec Change: from 1 Amp max to 1.5 A, and from 100 Ma to 170 Ma typical. Changed specs to <i>SI Metric System</i> .
4	6 Dec 00	Editorial throughout. Section 1, Specifications: Changed length from 5.60" to 5.85" to add dimension of flex cable extension. Section 2: Changed Figure 2-3 to reflect flex cable extension. Changed Figure 2-7 to add Red and Green callouts to LED. Changed Figure 2-8, 7-pin connector to reflect pin numbers and locking tabs.
5	22 Feb 01	Sec 1: Deleted P/N 16050327, added P/Ns 16050330, 16050337. Accessories: Changed 2-disk set to 4-disk set. Specifications, Dimensions: Changed width from 3.26" to 3.27"; Height from 2.17" to 2.18"; Weight from 15.33 oz to 15.4 oz and Bezels Wts. From 1.37 to 1.40 oz. Sec 2: Changed Figure 2-1 to Bezel Options. Changed Fig 2-2 Bezel Width from 3.264" to 3.27" and height from 2.17" to 2.18". Fig 2-3 Bezel width from .98" to 1.00". Sec 3: Changed "Section 3" to "Appendix A". Changed dwg (Fig A-1) to include polarity pin (+).
6	26 Apr 01	Changed illustrations throughout for clarity and added "D" Bezel. Front Matter: Changed warranty Address to 20801 S. Annalee. Added EMVCo statement. Editorial corrections Sec 1: To configurations added P/N 16050329 "D" Bezel. Specifications: Added "B", "C", and "D" bezel dimensions and weights.
7	16 Aug 01	Section 2, Fig 2-8, Corrected dimensions on D inner panel opening: Changed 4.00" to 3.745" and Changed 2.00" to 1.873".
8	2 May 02	Section 1: Added JIS to Specifications

(Continued)

### REVISIONS (Continued)

9	09 May 03	Front Matter: Added ISO line to logo, changed Tech Support phone number, added new warranty statement; Sec 2: Changed converted values in Figures 2-3, 2-4, 2-5, 2-6 and 2-8; Appendix A, Changed converted value in Figure A-3.
10	17 Feb 04	Options: Added paragraph: "In the special case where the card eject capacitor is being used..."
11	23 Jun 04	Editorial throughout. Sec 1, Added USB Power Cable, CDs for drivers, and Internet P/Ns for downloads. Added USB description and use.

### **Limited Warranty**

MagTek, Inc. warrants that the Product described in this document is free of defects in materials and workmanship for a period of one year from the date of purchase where the date of purchase is defined as the date of shipment from MagTek. During this warranty period, MagTek shall, at their option, repair or replace without charge for either parts or labor, any failure, malfunction, defect or nonconformity which prevents the product from performing in accordance with MagTek's published technical specifications and manuals.

This warranty does not apply to wear of the magnetic read head. This warranty shall not apply if the product is modified, tampered with, or subject to abnormal working conditions. This warranty does not apply when the malfunction results from the use of the Product in conjunction with ancillary or peripheral equipment where it is determined by MagTek that there is no fault in the Product itself.

Notification by the Customer to MagTek of any condition described above should be directed to the Customer's MagTek Sales Representative or to MagTek's Help Desk at (651) 415-6800. If the Product is to be returned from the Customer to MagTek, a returned material authorization (RMA) will be issued by MagTek. The Customer shall be responsible for shipping charges to MagTek, (20801 S. Annalee Ave., Carson, CA 90746). MagTek shall be responsible for shipping charges back to the Customer.

Repair or replacement as provided under this warranty is the exclusive remedy. This warranty is in lieu of all other warranties, express or implied.

## FCC WARNING STATEMENT

This equipment has been tested and found to comply with the limits for Class A digital device, pursuant to Part 15 of FCC Rules. These limits are designed to provide reasonable protection against harmful interference when the equipment is operated in a commercial environment. This equipment generates, uses, and can radiate radio frequency energy and, if not installed and used in accordance with the instruction manual, may cause harmful interference to radio communications. However, there is no guarantee that interference will not occur in a particular installation.

## FCC COMPLIANCE STATEMENT

This device complies with Part 15 of the FCC Rules. Operation of this device is subject to the following two conditions: (1) This device may not cause harmful interference; and (2) this device must accept any interference received, including interference that may cause undesired operation.

## CANADIAN DOC STATEMENT

This digital apparatus does not exceed the Class A limits for radio noise for digital apparatus set out in the Radio Interference Regulations of the Canadian Department of Communications.

Le présent appareil numérique n'émet pas de bruits radioélectriques dépassant les limites applicables aux appareils numériques de la classe A prescrites dans le Règlement sur le brouillage radioélectrique édicté par le ministère des Communications du Canada.

## CE STANDARDS

Testing for compliance to CE requirements was performed by an independent laboratory. The unit under test was found compliant to Class A.

## UL/CSA

This product is recognized per Underwriter Laboratories and Canadian Underwriter Laboratories 1950.

## EMVCo APPROVAL STATEMENT

EMVCo approval of the interface module (IFM) contained in this Terminal shall mean only that the IFM has been tested in accordance with the EMV Level 1 Specifications, Version 3.1.1, as of the date of testing. EMVCo approval does not under any circumstances include any endorsement or warranty regarding the completeness of the approval process or the functionality, quality or performance of any particular product or service. EMVCo does not warrant any products or services provided by third parties. EMVCo approval does not under any circumstances include or imply any product warranties from EMVCo, including, without limitation, any implied warranties of **merchantability, fitness for purpose, or non-infringement**, all of which are expressly disclaimed by EMVCo. All rights and remedies regarding products and services which have received EMVCo approval shall be provided by the party providing such products or services, and not by EMVCo.

## TABLE OF CONTENTS

<b>SECTION 1. FEATURES AND SPECIFICATIONS</b> .....	<b>1</b>
CONFIGURATIONS .....	1
STANDARD FEATURES.....	1
ACCESSORIES.....	2
RELATED DOCUMENTS.....	2
MOTORIZED TRANSPORT.....	2
RS-232 INTERFACE.....	2
USB INTERFACE.....	3
TEST LED.....	3
EXTERNAL BEZEL LED.....	3
FLASH UPGRADABLE.....	3
SMARTCARD INTERFACE.....	3
ONBOARD SAM INTERFACE.....	4
EXTERNAL SAM INTERFACE.....	4
MAGNETIC STRIPE READER.....	4
POWER FAILURE CARD EJECTION SYSTEM.....	4
FRONT GATE.....	4
CARD POSITION SENSORS.....	4
Front Card Present Sensor.....	5
Middle Card Present Sensor.....	5
Rear Card Present Sensor.....	5
SPECIFICATIONS.....	5
<b>SECTION 2. INSTALLATION</b> .....	<b>9</b>
MECHANICAL MOUNTING.....	9
BEZELS.....	10
ELECTRICAL CONNECTIONS.....	18
Connectors and LEDs.....	18
RS-232 Cable.....	19
USB Cable.....	19
Power Supply.....	20
Power-Fail Capacitor Connector, 2-Pin.....	21
External SAM Port Connector, 24-Pin.....	21
<b>APPENDIX A. OPTIONS</b> .....	<b>23</b>
POWER FAILURE CARD EJECT SYSTEM.....	23
SAM RANCH.....	25
<b>APPENDIX B. BEZEL A DIMENSIONS</b> .....	<b>27</b>

## FIGURES

Figure 1-1. IntelliStripe 320 with "D" and "C" Bezels -----	viii
Figure 2-1. Bezel Options-----	9
Figure 2-2. Bezel Mounting Dimensions – B, C, and D Bezels-----	10
Figure 2-3. "B" Bezel Mounting – Top, Side, and Bottom Views -----	11
Figure 2-4. "C" Bezel Mounting – Top, Side, and Bottom Views -----	12
Figure 2-5. "D" Bezel Mounting – Top, Side, and Bottom Views -----	13
Figure 2-6. Panel Opening for Mounting "B" Bezel-----	14
Figure 2-7. Panel Opening for Mounting "C" Bezel-----	15
Figure 2-8. Panel Openings for Mounting "D" Bezel -----	16
Figure 2-9. Mounting Configurations-----	17
Figure 2-10. Connector and LED locations-----	18
Figure 2-11. RS-232 Cable, P/N 16051408 -----	19
Figure 2-12. USB Cable, P/N 16051425 -----	20
Figure 2-13. Power Supply -----	21
Figure A-1. Card Eject Capacitor -----	23
Figure A-2. SAM Ranch-----	25
Figure A-3. SAM Ranch Dimensions -----	26
Figure B-1. Bezel "A" Dimensions -----	27

## TABLES

Table 1-1. Specifications-----	6
Table 2-1. Pin List for RS-232 IntelliStripe 320 Connectors, P/N 16051408 -----	19
Table 2-2. Pin List for USB IntelliStripe 320 Connectors, P/N 16051425 -----	20

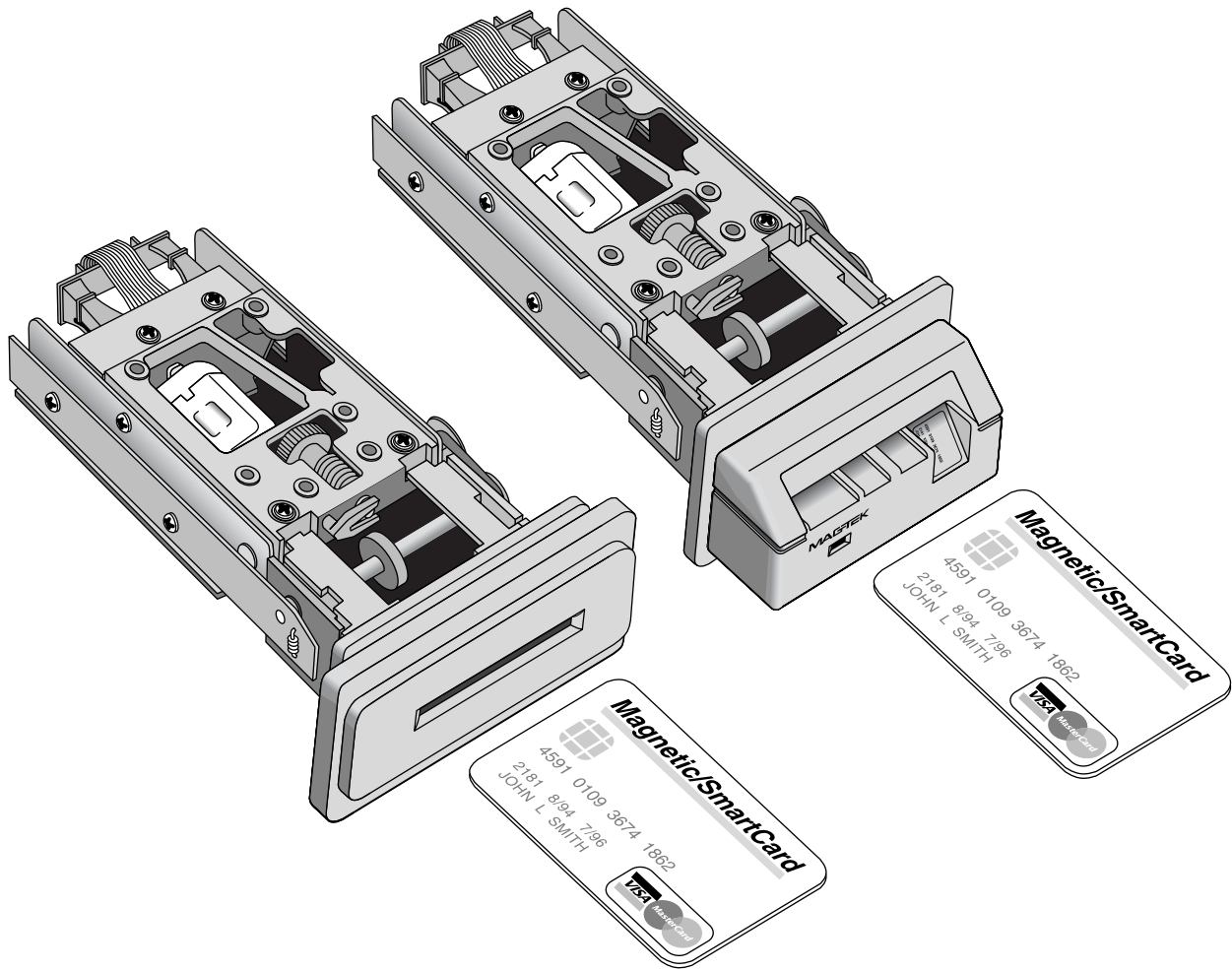

**Figure 1-1. IntelliStripe 320 with “D” and “C” Bezels**



# SECTION 1. FEATURES AND SPECIFICATIONS

The IntelliStripe 320 is a hybrid, motorized reader that supports both magnetic stripe cards and smartcard technologies simultaneously. The IntelliStripe 320 Reader can be used in environments such as self-service kiosks, vending machines, and POS terminals.

The Reader can be used as a smartcard device only, which will provide an intelligent read/write interface to the user smartcard and can provide read/write access to optional SAMs (Security Access Modules).

The IntelliStripe 320 can also perform functions related to a “reload station”. In this environment, financial accounts will be accessed by magnetic-stripe cards or financial cards, and then the monetary value will subsequently be loaded onto a secondary smartcard.

## CONFIGURATIONS

Part Number	Description
16050327	IntelliStripe 320, 3Trk, RS-232, with B Bezel, Stripe UP
16050328	IntelliStripe 320, 3Trk, RS-232, with C Bezel, Stripe down
16050329	IntelliStripe 320, 3Trk, RS-232, with D Bezel

## STANDARD FEATURES

Standard features of the IntelliStripe 320 are as follows:

- Motorized transport
- RS232 and USB interfaces
- On board intelligence for transporting large blocks of data using a defined protocol and command set
- Flash upgradable
- 8 Smart Card Contacts for reading ISO contact locations
- On board SAM (Security Access Module)
- External SAM port for optionally adding up to six external SAMs
- Supports all magnetic stripe 3-track combinations
- Front Card Gate prevents coins, dust, moisture, and debris, from entering the unit – gate resists opening except when ISO-size card enters the unit
- Power failure card ejection system (requires optional external capacitor)
- Test LED
- External Bezel LED

## **ACCESSORIES**

Other part numbers that may be shipped with the unit are as follows:

- RS232 / Power cable—6 foot IntelliStripe 320 host port to 9 pin D female RS232 and 2.5mm power jack, part number 16051408
- USB / Power cable – 6 foot, IntelliStripe 320 host port to USB-A and 2.5 mm power jack, part number 16051425
- Power Supply—Autoranging 100V-250V, regulated, 12VDC, 2.5mm plug, part number 64300080. Requires adapter to mate with power outlet; use Adapter/Power Cord part number 71100001, for North American applications
- Drivers, MCP, CD, part number 30037473 (or 99510016 from MagTek.com)
- Demo Software, IntelliStripe Picture Demo, CD, part number 30037472 (or 99510015 from MagTek.com)
- Communications Software, MCP3 Program, 4-disk set, part number 30037442
- Sam Ranch—For adding up to 6 additional SAMs, part number 16055501
- Sam Ranch Cable—For connecting the SAM Ranch, part number 16051409

## **RELATED DOCUMENTS**

The following documents are relevant to this product:

99875163	MCP, Serial Transport Protocol, Reference Manual
99875164	Communication Protocol, Driver Reference Manual
99875168	IntelliStripe 320, Command Reference Manual

## **MOTORIZED TRANSPORT**

The Reader has a command-driven motorized transport. The transport keeps the card from the user during a transaction but returns the card when the transaction is completed.

## **RS-232 INTERFACE**

The unit communicates to the host through an RS-232 interface. The device uses 8 data bits, 1 stop bit, even parity. The unit can automatically sync to baud rates 9600, 14400, 19200, 28800, 38400, and 57600. See MCP Driver Reference Manual, Part Number 99875164, and MCP Serial Transport Protocol Reference Manual, Part Number 99875163, for more details.

## **USB INTERFACE**

The IntelliStripe 320 can communicate with a PC via a USB connection by using the MagTek USB conversion cable (P/N 16051425). When this cable is attached to the PC, the corresponding MagTek USB driver will be required. This driver can be obtained from [www.magtek.com](http://www.magtek.com) in the *Support | Software | Programming Tools* section. Copy these files to a location on your hard disk. When the IntelliStripe 320 cable is attached, follow the prompts on the screen to browse to the location where the USB driver files have been copied.

After installation, the IntelliStripe 320 will be available as a virtual COM port. The actual COM port number can be obtained by opening the Windows *Device Manager* and clicking on the plus (+) sign next to **Ports (COM & LPT)**. When using the MCP driver, you will define an instance referring to this port. See MCP Driver Reference Manual, Part Number 99875164, and MCP Serial Transport Protocol Reference Manual, Part Number 99875163, for more details.

## **TEST LED**

A Test LED, designated D5 will blink green when the unit is powered up. This indicates that the unit is in its standard operating mode and is fully operational. This feature allows field technicians to quickly verify that the device is operational.

## **EXTERNAL BEZEL LED**

The External bezel LED is shown in Section 2, Figure 2-10. The LED can be set to red, green or off. See IntelliStripe 320 Command Reference Manual, Part Number 99875168, for more details.

## **FLASH UPGRADABLE**

The unit's firmware is in-system Flash Upgradable. This allows the unit's firmware to be upgraded in a field environment. This may be required in cases when new smartcard specifications reach the marketplace.

## **SMARTCARD INTERFACE**

The reader provides connections to all 8 ICC contacts as defined by ISO 7816 specifications. The Reader supports ISO7816 T=0 and T=1 cards not requiring  $V_{PP}$ , with a speed range of 9600 bps (baud per second) to 115200 bps. It also supports a variety of common memory card types. See IntelliStripe 320 Command Reference Manual, Part Number 99875168, for more details.

### ONBOARD SAM INTERFACE

The Reader provides a socket for one on board SAM. The SAMs comply to ISO 7816-3 (1997) electrical requirements and do not require  $V_{PP}$ . T=0 and T=1 are fully supported with a speed range from 9600 bps to 115200 bps. See IntelliStripe 320 Command Reference Manual, Part Number 99875168, for more details.

### EXTERNAL SAM INTERFACE

The Reader provides an interface for adding up to six additional SAMs. The SAMs comply to ISO 7816-3 (1997) electrical requirements and do not require  $V_{PP}$ . T=0 and T=1 are fully supported with a speed range from 9600 bps to 115200 bps. See Appendix A and IntelliStripe 320 Command Reference Manual, Part Number 99875168, for more details.

### MAGNETIC STRIPE READER

The Reader can read up to three tracks of magnetic stripe card data. See IntelliStripe 320 Command Reference Manual, Part Number 99875168, for more details.

### POWER FAILURE CARD EJECTION SYSTEM

The Reader has a power-failure card-ejection system. This system will automatically eject a card when a power failure occurs. To enable this system, an optional external capacitor needs to be connected to the reader. See Appendix A for more details.

### FRONT GATE

The Front Card Gate prevents coins, dust, moisture, and debris, from entering the unit. The gate resists opening except when ISO-size card enters the unit

#### *Note*

*If the front-gate option is installed, the IntelliStripe 320 Reader will be incapable of reliably reading mag-stripe cards during the card-ejection cycle. (Reliable mag-stripe reading will only be possible during the card-insertion cycle). If mag-stripe reading is required during the card-ejection cycle, then the product must be ordered without the front-gate option.*

### CARD POSITION SENSORS

The reader contains three card position sensors: front card present sensor, middle card present sensor, and rear card present sensor.

### **Front Card Present Sensor**

An optical sensor that indicates whether a card is present at the front (insertion) end of the card transport. See IntelliStripe 320 Command Reference Manual, Part Number 99875168, for more details.

### **Middle Card Present Sensor**

An optical sensor that indicates whether a card is present in the middle of the card transport. See IntelliStripe 320 Command Reference Manual, Part Number 99875168, for more details.

### **Rear Card Present Sensor**

An optical sensor that indicates whether a card is present at the rear (smart card contacts) end of the card transport. See IntelliStripe 320 Command Reference Manual, Part Number 99875168, for more details.

## **SPECIFICATIONS**

Specifications for the Reader are listed in Table 1-1.

**Table 1-1. Specifications**

<b>DATA FORMAT SPECIFICATIONS</b>	
<b>Reader Configuration</b>	<b>Data Format Specifications*</b>
Mag-Stripe Functions: Track 1,2,3 only	ISO/AAMVA/CDL/JIS formats ISO 7810, 7811, JIS x 6302 Type 2
Smartcard Functions:	ISO 7816 T=0 and T=1 protocols, many popular memory cards EMVCo Level 1 Approval
* ISO (International Standards Organization), AAMVA, (American Association of Motor Vehicle Administrators), CDL (California Drivers License), JIS (Japanese Industrial Standard)	
<b>OPERATIONAL</b>	
Card Speed:	10 IPS (25,4 cm/sec) typical
Recording Method	Two-frequency coherent phase (F2F)
MTBF	Electronics: 125,000 hours Head: 1,000,000 passes (500,000 Insertion Cycles) SC contacts: 1,000,000 passes
<b>ELECTRICAL</b>	
Input Voltage:	12.0 VDC $\pm$ 5%
Current:	1.5 A max 170 mA typical (with motor off)
Optional Auxiliary Power-Fail Card-Eject Capacitor:	Recommended capacitor value: 68000 $\mu$ F rated at 16 volts.
<b>MECHANICAL</b>	
Chassis Mounting Options	With "A" and "B" Bezel, screws mounted from under unit, magstripe up and to the left
	With "A" and "C" Bezel, screws mounted from above unit, magstripe down and to the right
	With "A" Bezel only, screws mounted from above or under unit.
	With "D" Bezel, screws mounted from above or under unit.
Dimensions (Core Chassis)	
Length (with "A" Bezel):	5.85" (148.59 mm) (includes flex cable connector overhang)
Width (with "A" Bezel):	3.26" (82.91 mm)
Height (with "A" Bezel):	2.17" (55.12 mm)
Length (with "B" or "C" Bezel):	6.83" (173.48 mm)
Width (with "B" or "C" Bezel):	3.26" (82.91 mm)
Height (with "B" or "C" Bezel):	2.17" (55.12 mm)
Length (with "D" Bezel):	6.26" (159.00 mm)
Width (with "D" Bezel):	4.00" (101.60 mm)
Height (with "D" Bezel):	2.17" (55.12 mm)
Cable Length (16051408):	6' $\pm$ 0.1' (1.83 m $\pm$ 0.03 m)
Adapter Cable Length (64300080):	6.25' (1.91 m)
Weight:	
Reader with "A" Bezel:	15.40oz. (436.58 g.)

## Section 1. Features and Specifications

"B" or "C" Bezel w/screws: "D" Bezel w/screws:	1.40 oz. (39.69 g.) 1.08 oz. (30.58 g.)
Reader Cable: SAM Ranch with Cable: AC Adapter Regulator with Power Cord:	4.15 oz. (117.76 g.) 2.90oz. (82.24 g.) 11.87 oz. (336.60 g.)
<b>ENVIRONMENTAL</b>	
Temperature Operating: Storage:	32 ° F to 122 ° F (0° C to 50° C) -40 ° F to 158 ° F (-40° C to 70° C)
Humidity Operating: Storage:	10% to 90% noncondensing 10% to 90% noncondensing
Altitude Operating: Storage:	0-10,000 ft. (0-3,048 m.) 0-50,000 ft. (0-15,240 m.)





## SECTION 2. INSTALLATION

The installation of the IntelliStripe 320 Motorized Reader includes mechanical and electrical connections.

### MECHANICAL MOUNTING

The "A" Bezel is always shipped with the unit. The "B," "C," or "D" Bezels may also be shipped with the unit, depending on requirements for card orientation. Figure 2-1 shows the configurations for mounting and card orientation:

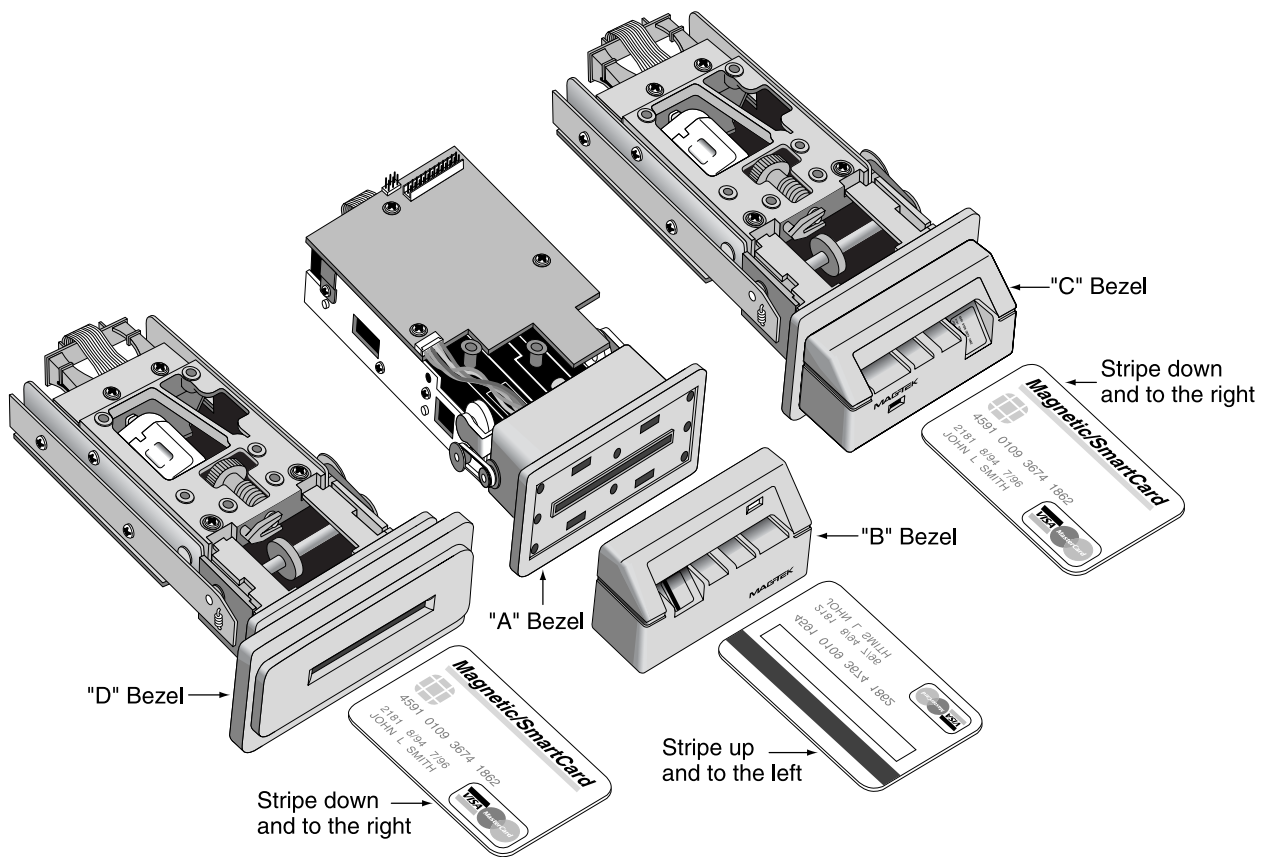

Figure 2-1. Bezel Options

## BEZELS

Dimensions and details of the three bezels are shown in Figure 2-2. The "A" Bezel will always be shipped with the unit ("A" bezel dimensions are shown in Appendix B.) Also, the "B," "C," or "D" Bezel may be shipped with the unit. The user may also design a bezel from dimensions in this section.

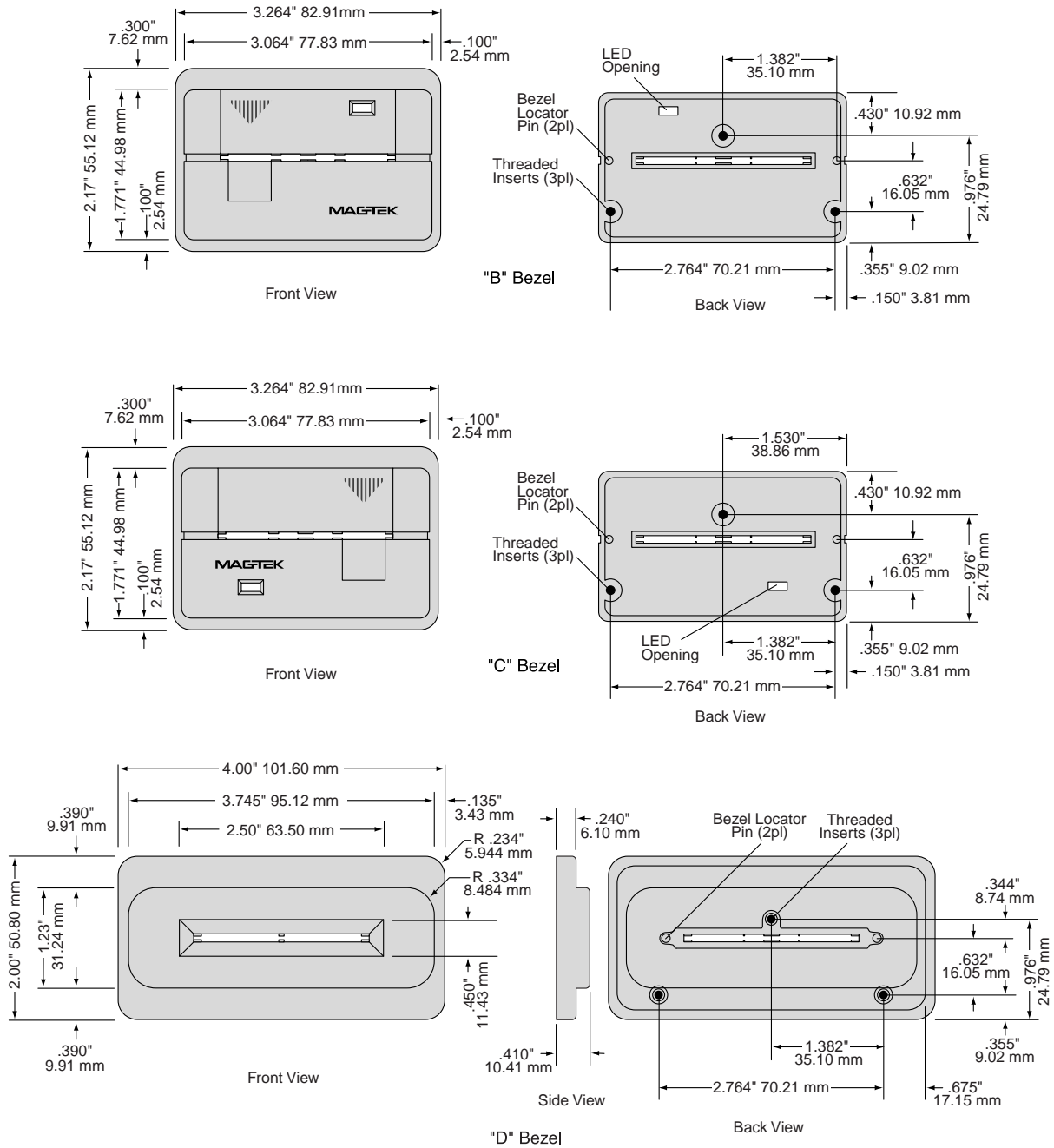

Figure 2-2. Bezel Mounting Dimensions – B, C, and D Bezels

Figure 2-3 shows the position for mounting the IntelliStripe 320 with the “B” Bezel attached. The mounting holes are shown in the bottom view. The "A" Bezel is attached to the unit by the "A" Bezel Retaining screws also shown in the bottom view.

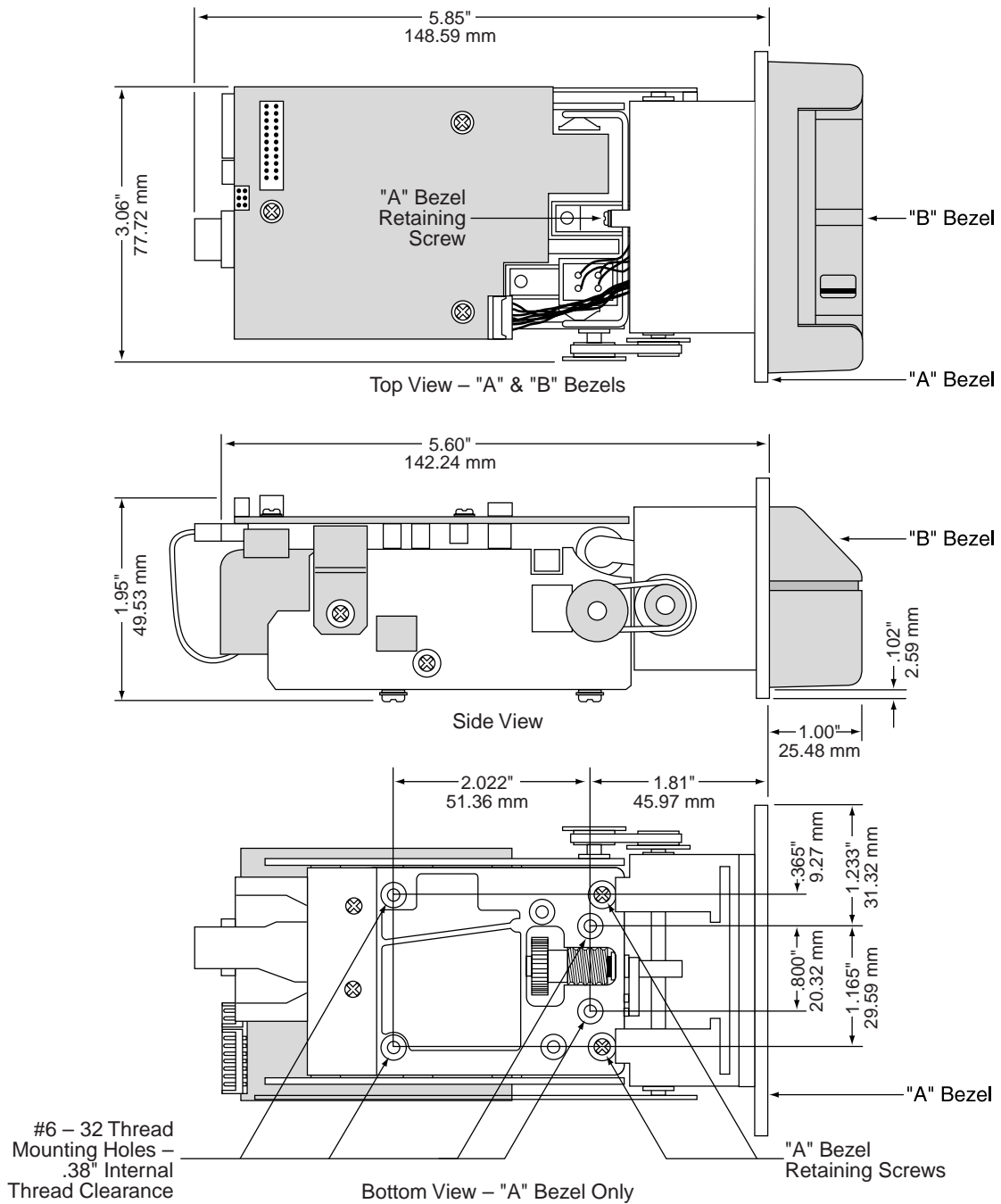
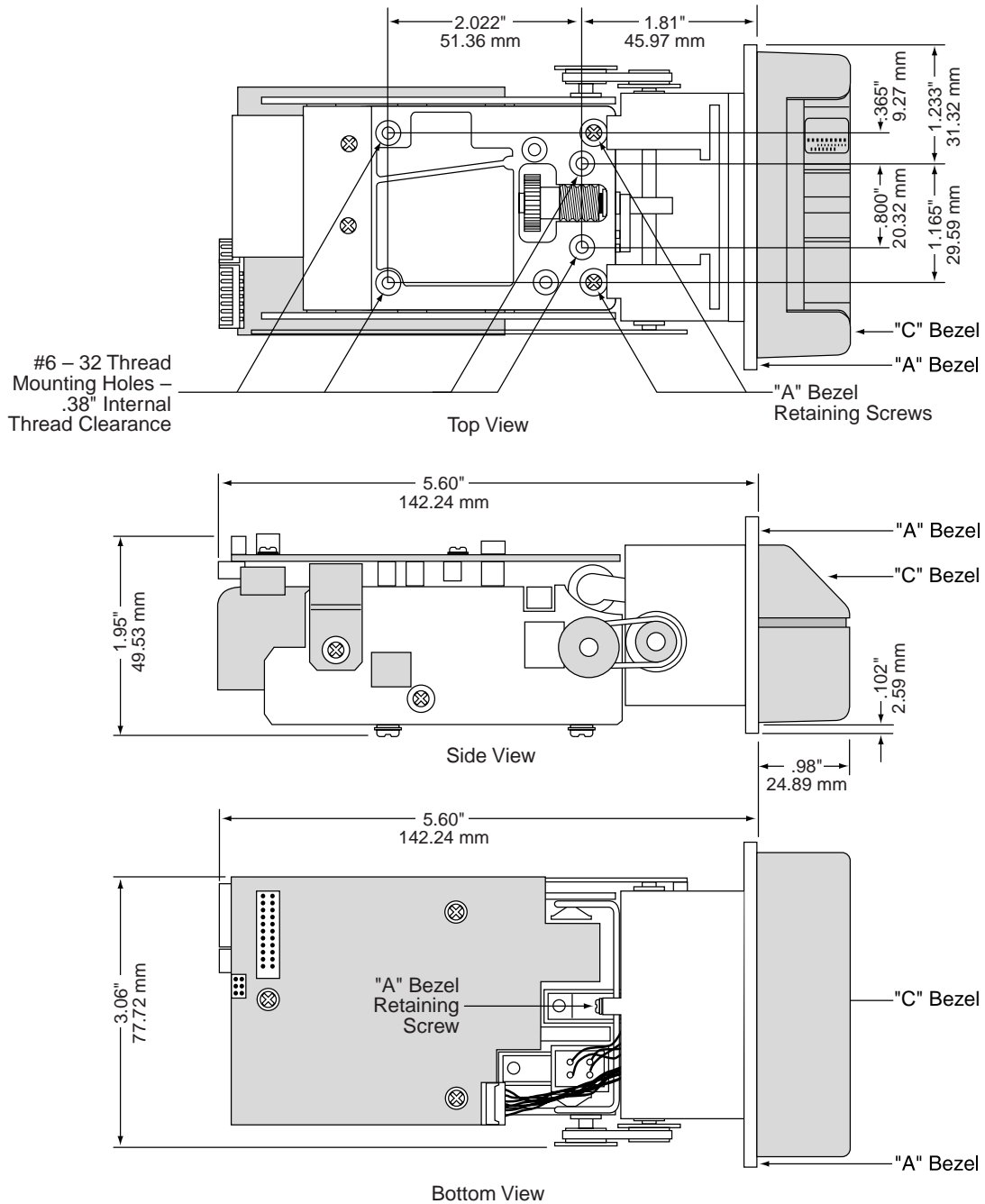

Figure 2-3. “B” Bezel Mounting – Top, Side, and Bottom Views

**IntelliStripe 320 Motorized Reader**

Figure 2-4 shows the position for mounting the IntelliStripe 320 with the "C" Bezel attached. The mounting holes are shown in the top view. The "A" Bezel is attached to the unit by the "A" Bezel Retaining screws also shown in the top view.



**Figure 2-4. "C" Bezel Mounting – Top, Side, and Bottom Views**

Figure 2-5 shows the position for mounting the IntelliStripe 320 with the “D” Bezel attached. The mounting holes are shown in the bottom view. The "A" Bezel is attached to the unit by the "A" Bezel Retaining screws also shown in the bottom view. Because the “D” Bezel is symmetrical, the unit may be mounted from the top or bottom, depending on the desired card orientation. (Note that no LED is used with the “D” Bezel configuration.)

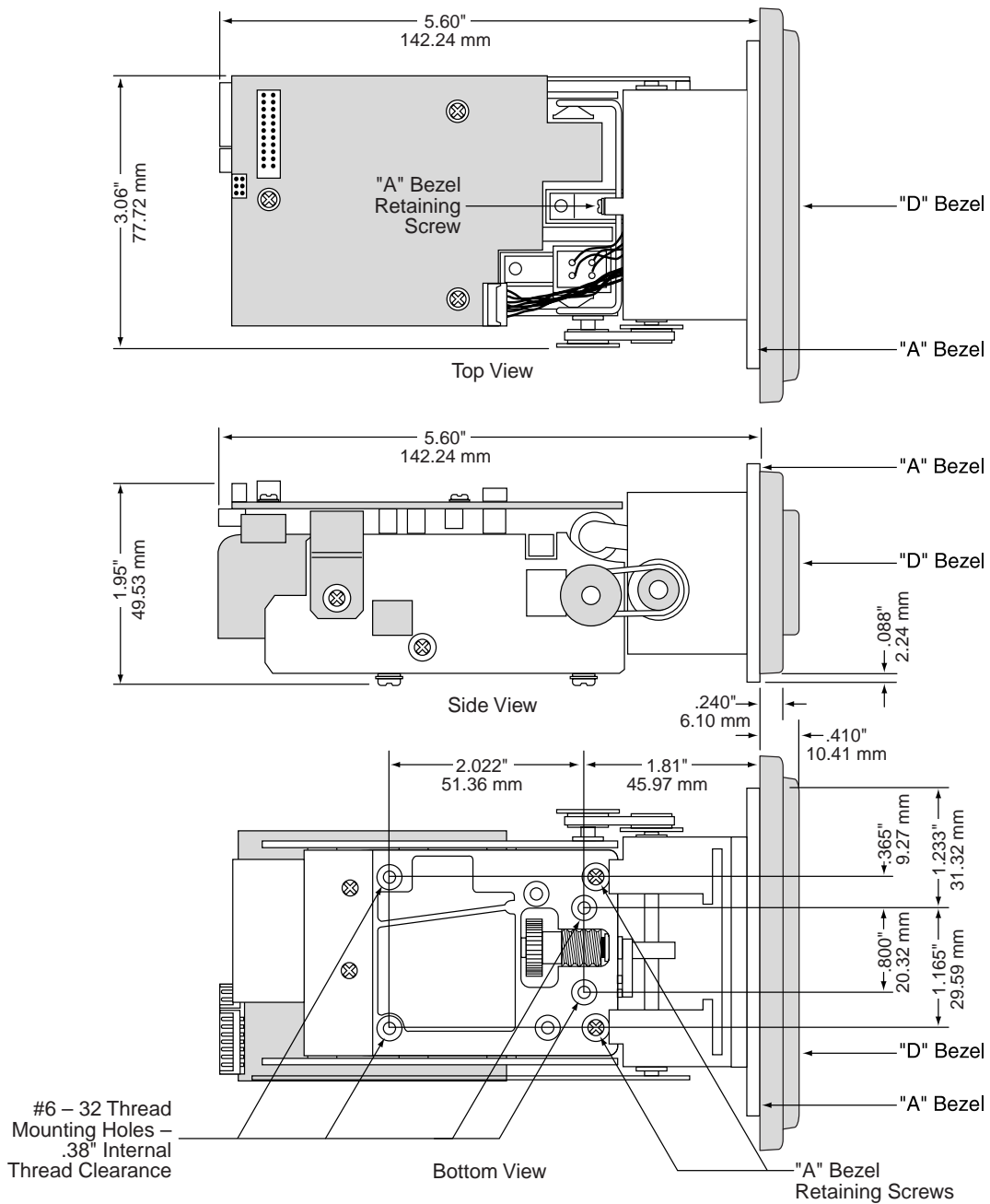
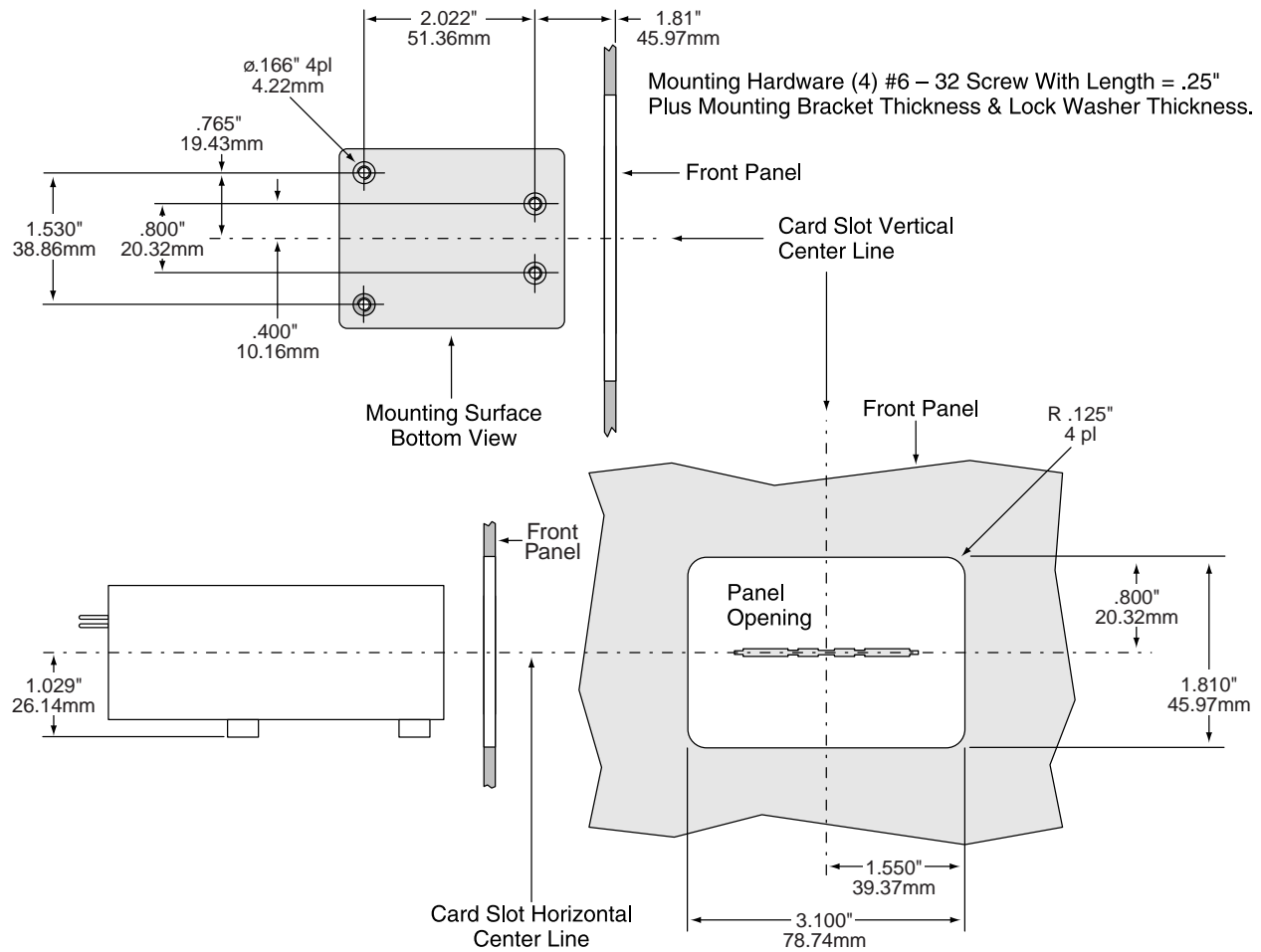

Figure 2-5. “D” Bezel Mounting – Top, Side, and Bottom Views

For "B" bezel configuration, the dimensions in Figure 2-6 are for the unit mounted from the backside of the panel. These dimensions include the dimensions from the centerline of the card slot to other areas for mounting the unit from the backside of the panel. Note the dimension from the *top* of the panel opening to the centerline. The same value in the "C" bezel is from the *bottom* of the panel opening to the centerline



**Figure 2-6. Panel Opening for Mounting "B" Bezel**

It is not necessary to remove the Bezels when mounting the unit. The "B" Bezel protrudes from the opening, and the "A" Bezel is positioned against the inside of the panel opening. The bracket should retain the unit so the "A" Bezel is held firmly against the inside of the panel.

For "C" bezel configuration, the dimensions in Figure 2-7 are for the unit mounted from the backside of the panel. These dimensions include the dimensions from the centerline of the card slot to other areas for mounting the unit from the backside of the panel. Note the dimension from the *bottom* of the panel opening to the centerline. The same value in the "B" bezel is from the *top* of the panel opening to the centerline

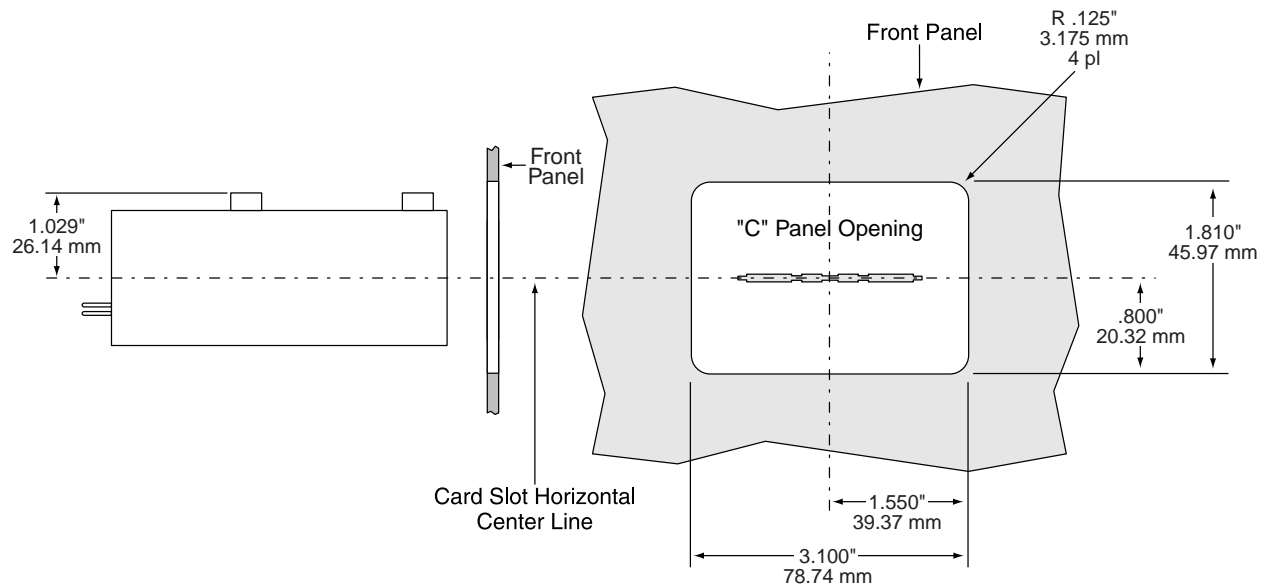

**Figure 2-7. Panel Opening for Mounting "C" Bezel**

It is not necessary to remove the Bezels when mounting the unit. The "B" or "C" Bezel protrudes from the opening, and the "A" Bezel is positioned against the inside of the panel opening. The bracket should retain the unit so the "A" Bezel is held firmly against the inside of the panel.

For "D" bezel configuration, the two sets of dimensions in Figure 2-8 are for units to be mounted from the backside of the panel. The openings are for mounting the outer or inner panel openings.

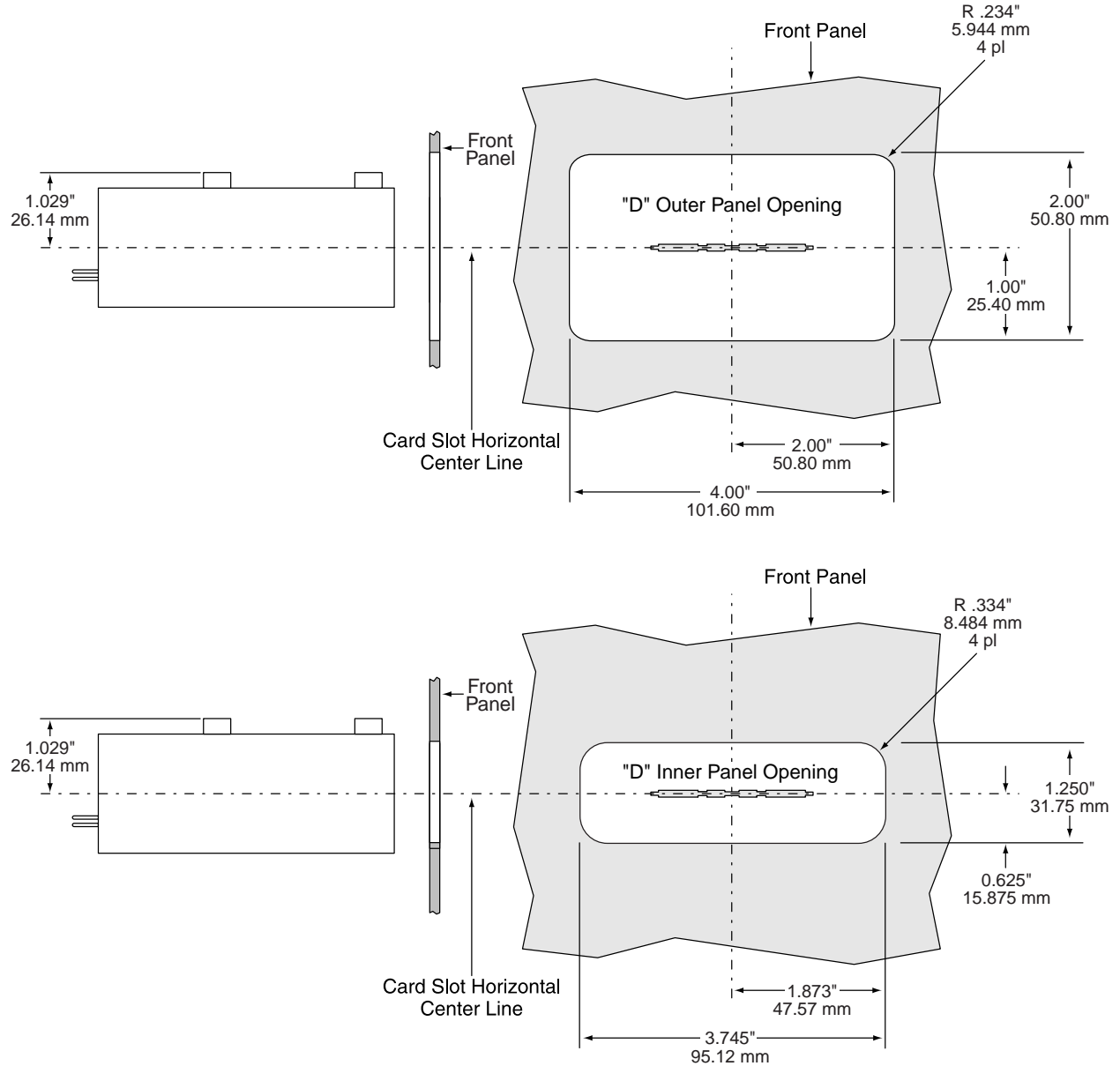

**Figure 2-8. Panel Openings for Mounting "D" Bezel**



Four #6-32 mounting screws, with 0.38 inch internal thread clearance, attach the bottom of the IntelliStripe 320 to a fixed position as indicated in Figure 2-9. If the "B" bezel is used, the mounting screws are inserted from under the IntelliStripe 320. If the "C" bezel is used, the IntelliStripe 320 is inverted, and the mounting screws are inserted from above the IntelliStripe 320.

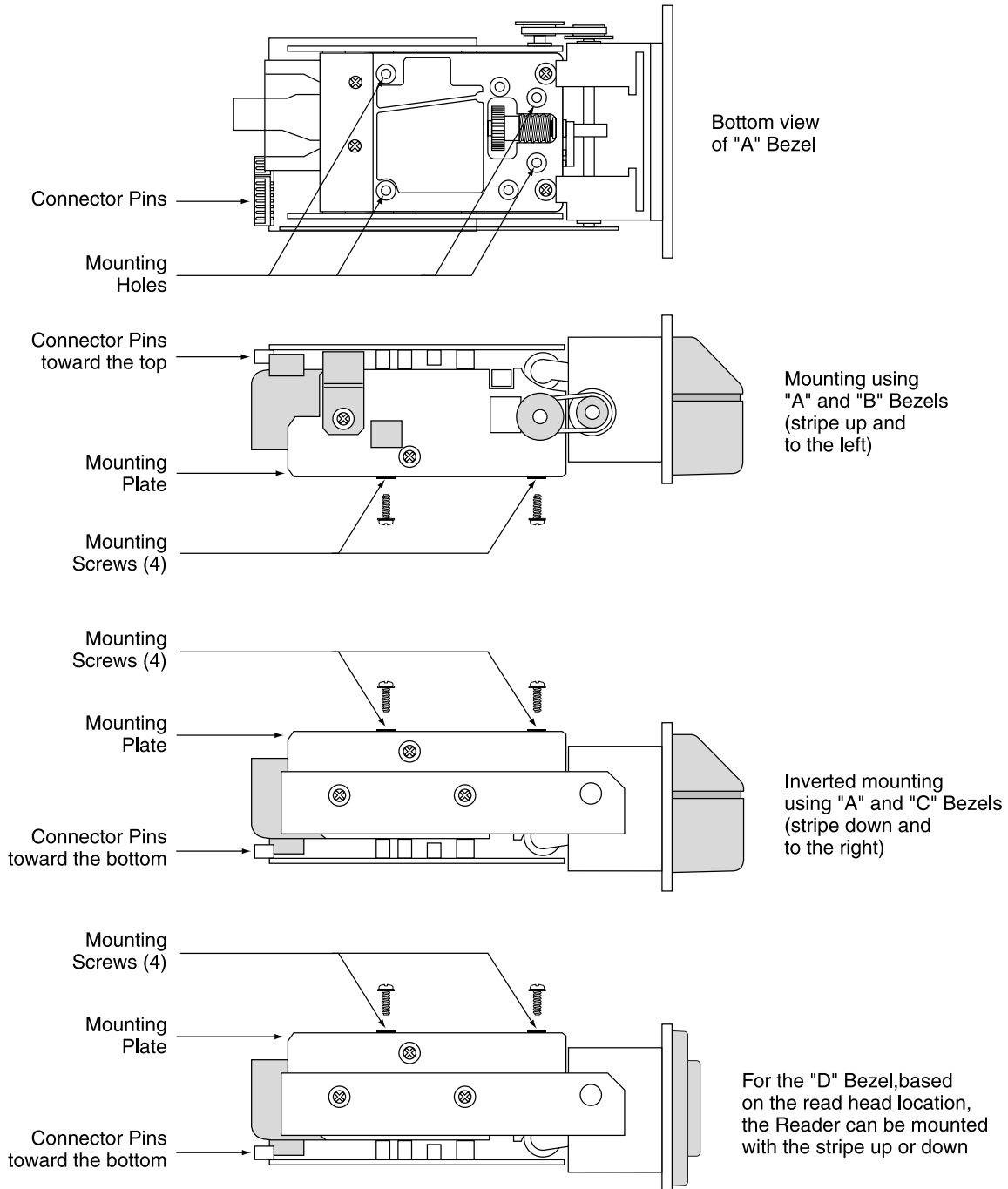

Figure 2-9. Mounting Configurations

## ELECTRICAL CONNECTIONS

### Connectors and LEDs

Figure 2-10 shows the positions of the connectors for the SAM socket, Sam Ranch, power-fail capacitor, and LEDs.

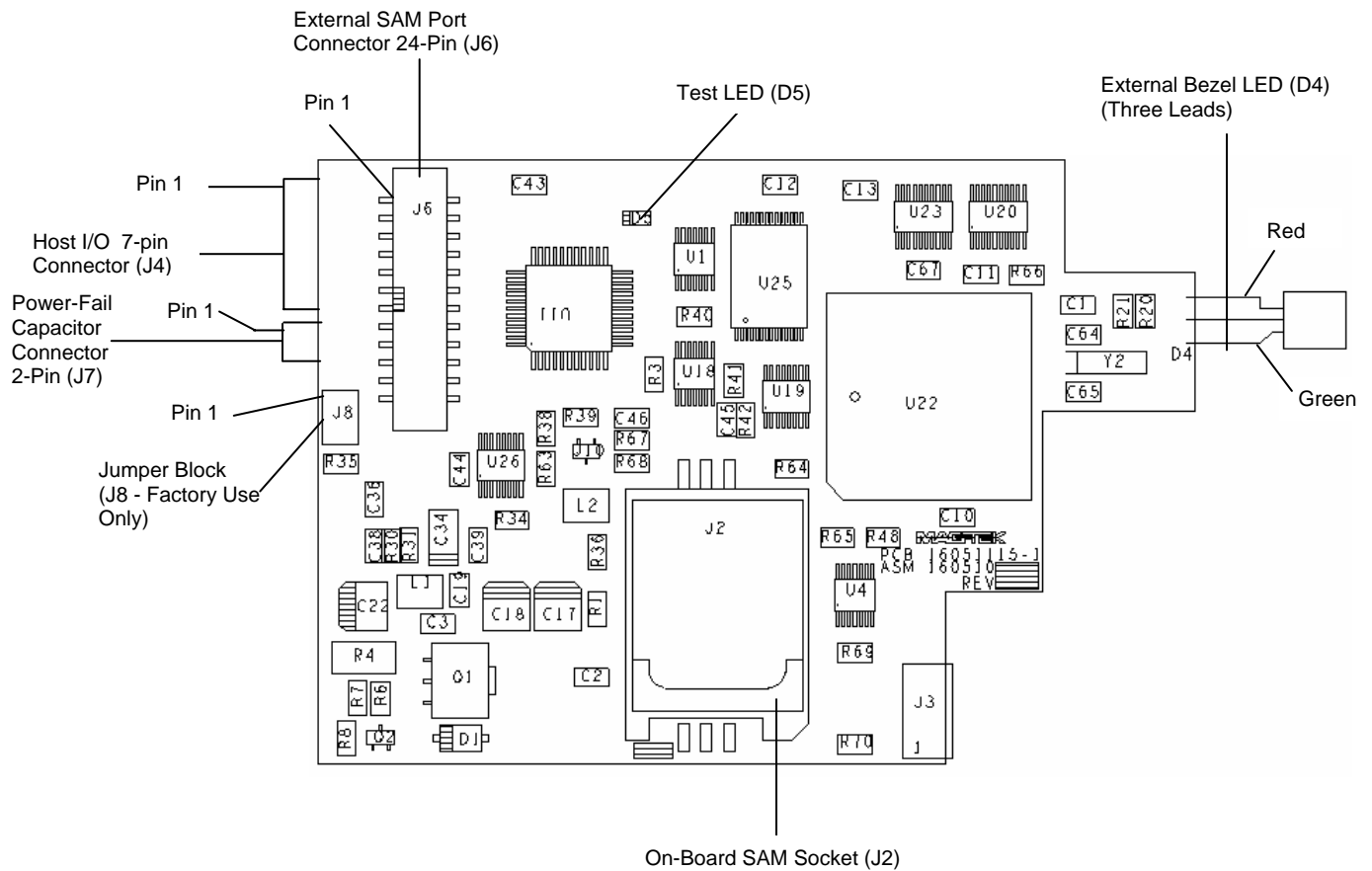
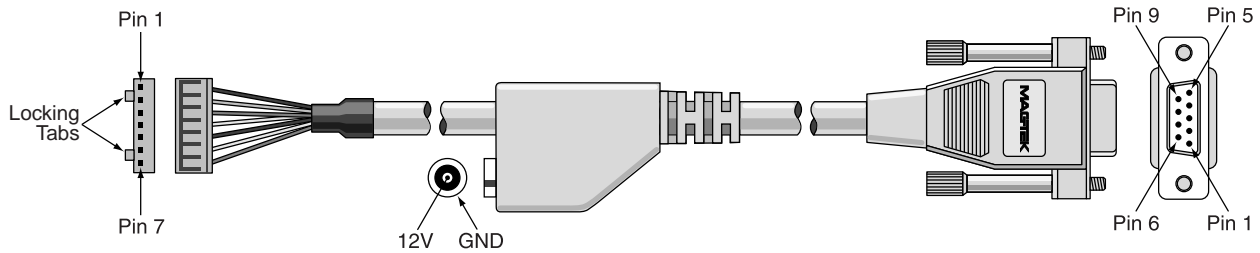

Figure 2-10. Connector and LED locations

### RS-232 Cable

Figure 2-11 shows the cable that connects the IntelliStripe 320 (7-pin connector) to the host (9-pin connector), P/N 16051408. The standard length of the cable is 6'.



**Figure 2-11. RS-232 Cable, P/N 16051408**

Table 2-1 lists the Connector Pin Numbers and Signal Names.

**Table 2-1. Pin List for RS-232 IntelliStripe 320 Connectors, P/N 16051408**

Molex 7 Pin (51065-0700)		DE-9 Female		2.5mm Power Jack	
Pin Number	Signal Name	Pin Number	Signal Name		
1	TXD	2	RXD		
2	+12V			CENTER PIN	+12V
3	PWR GND			SHELL	GND
4	RXD	3	TXD		
5	RTS	8	CTS		
6	CTS	7	RTS		
7	SIGNAL GND	5	GND		
		6	DSR		
		4	DTR		

### USB Cable

Figure 2-12 shows the cable that connects the IntelliStripe 320 (7-pin connector) to the USB port, P/N 16051425. The standard length of the cable is 6'.

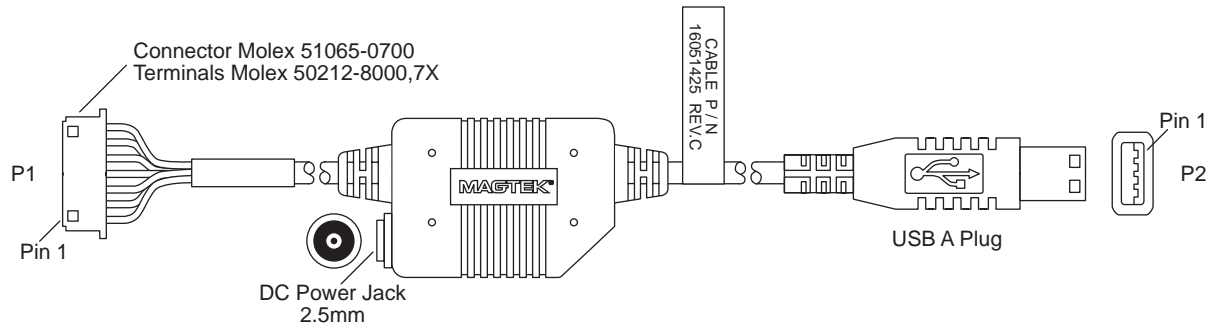

**Figure 2-12. USB Cable, P/N 16051425**

Table 2-2 lists the connector pin numbers and signal names.

**Table 2-2. Pin List for USB IntelliStripe 320 Connectors, P/N 16051425**

Molex 7 Pin (51065-0700)		DC Jack		USB-A	
Pin Number	Signal Name			Pin Number	Signal Name
1	TXD			1	VBUS
2	+12V	CENTER PIN	+12V	2	D-
3	PWR GND	SHELL	GND	3	D+
4	RXD			4	GND
5	RTS				
6	CTS				
7	SIGNAL GND				

## Power Supply

The Power Supply, P/N 64300080, 100V–240V regulated, 12VDC @ 1.5 Amps, with special 2.5 mm plug is shown in Figure 2-13. The AC power cord , P/N 71100001, is for use in North America. Other users must supply their own cord (requires an IEC-320-C13 connector at the power supply).

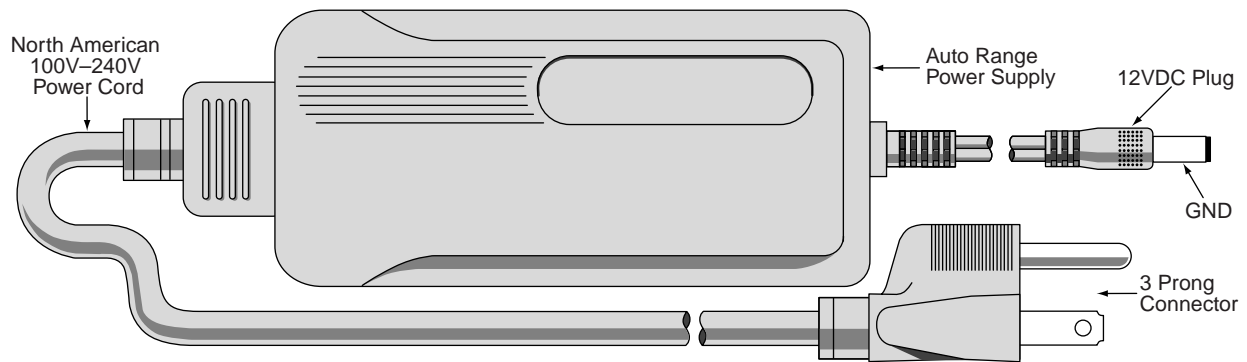

**Figure 2-13. Power Supply**

### **Power-Fail Capacitor Connector, 2-Pin**

The Power-Fail Capacitor connector, J7, connects to an optional external capacitor that is used to eject the card during a power failure. Pin 1 connects to the positive side of the capacitor and pin 2 connects to the negative side.

### **External SAM Port Connector, 24-Pin**

The external SAM port connector, J6, connects to an optional SAM ranch board through a 24-conductor cable. Up to six additional SAMs can be connected through this port.



## APPENDIX A. OPTIONS

Options include a capacitor for the Power-Failure Card-Eject System, and the SAM Ranch.

### POWER FAILURE CARD EJECT SYSTEM

The externally mounted power-fail capacitor is shown in Figure A-1.

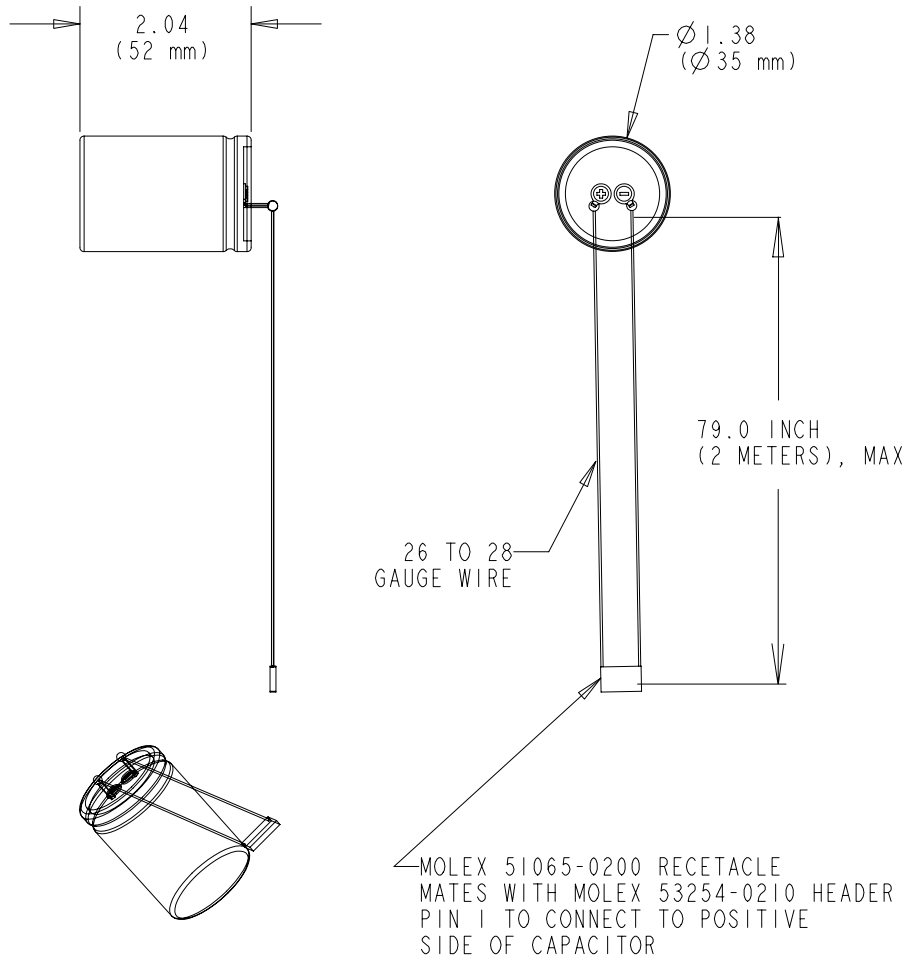

**Figure A-1. Card Eject Capacitor**

The power-failure card-eject system ejects a card during a power failure. Card ejection is triggered when the power to the reader fails. An external backup capacitor is required for this option to function. This capacitor can be connected to the reader through a header on the board. In case of power failure, the capacitor automatically ejects the card. The user must determine the wire length required for their specific application. The recommended capacitor value is 68000uF rated at 16 volts.

## **IntelliStripe 320 RS232 Motorized Reader**

---

In the special case where the card eject capacitor is being used and the 12 volt supply to the IntelliStripe 320 is being shared with another device in the system, a diode needs to be connected in series with the 12 volt supply line to the IntelliStripe 320. This is required to prevent the card eject capacitor from discharging into the external device when a power failure occurs. If the card eject capacitor discharges into a external device, the capacitor may not have enough power left to eject a card. This diode should be a low voltage drop (.3 volt ) type in order to make the IntelliStripe 320 input voltage still meet the specified 12 volts +- 5%. Using a high voltage drop (.6 volt) type may cause false power failure detections in the IntelliStripe 320. This diode should be rated at 1.5 amps or higher.



## SAM RANCH

The SAM (Security Access Module) Ranch is shown with the IntelliStripe in Figure A-2. SAMs are inserted into specific sockets. To connect a SAM, proceed as follows:

1. Slide the metal latch away from the hinge.
2. Flip open the hinged lid.
3. Slide the SAM into the lid.
4. Close the lid.
5. Slide the metal latch toward the hinge. The SAM will click into place.

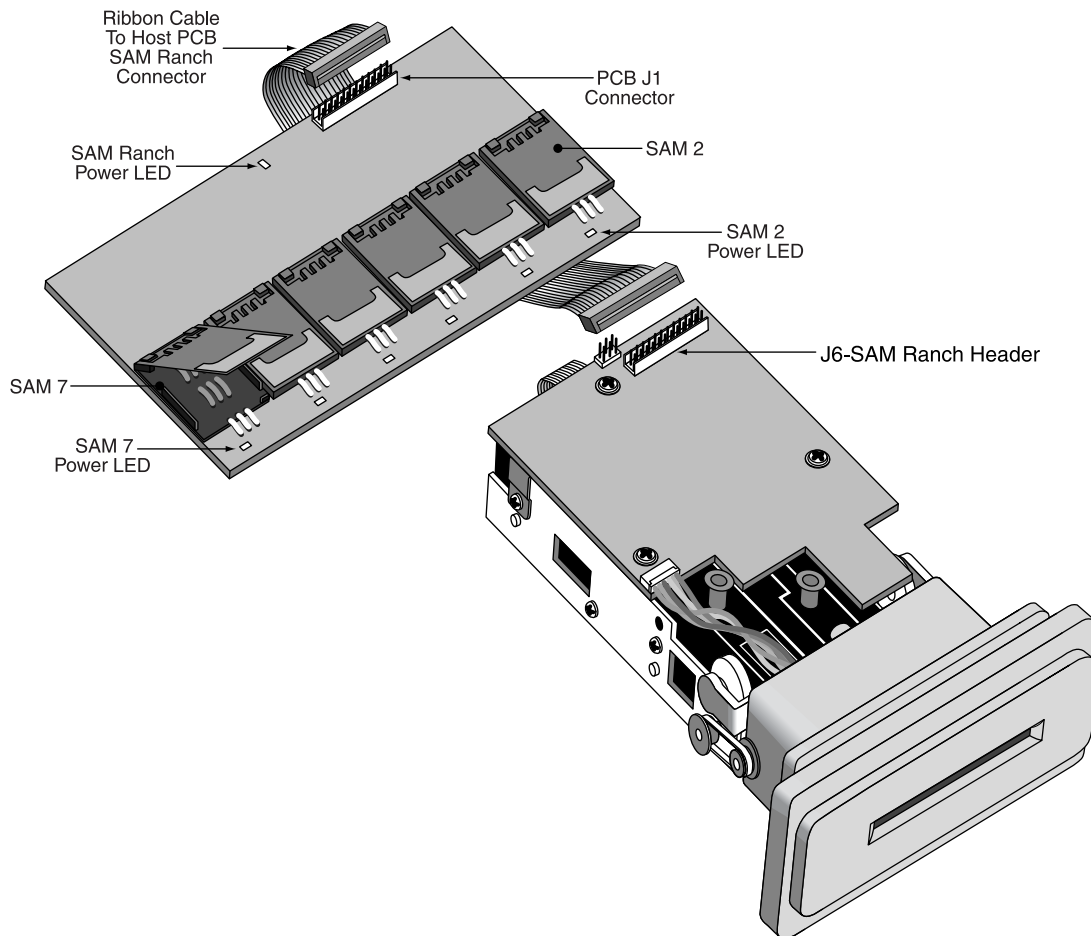
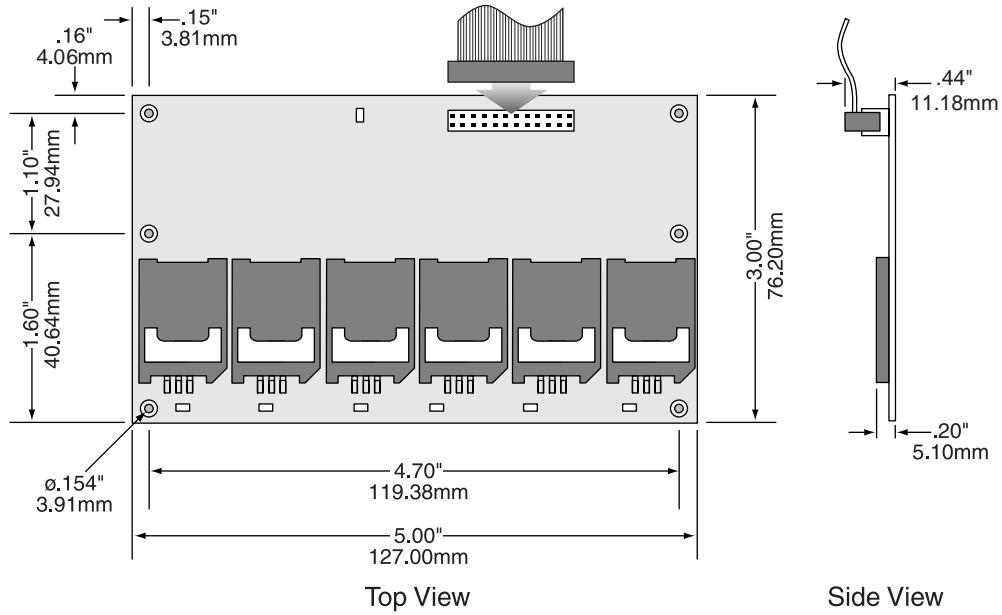

Figure A-2. SAM Ranch

The Dimensions of the SAM Ranch are shown in Figure A-3.



**Figure A-3. SAM Ranch Dimensions**

## APPENDIX B. BEZEL A DIMENSIONS

The "A" Bezel dimensions are shown in Figure B-1.

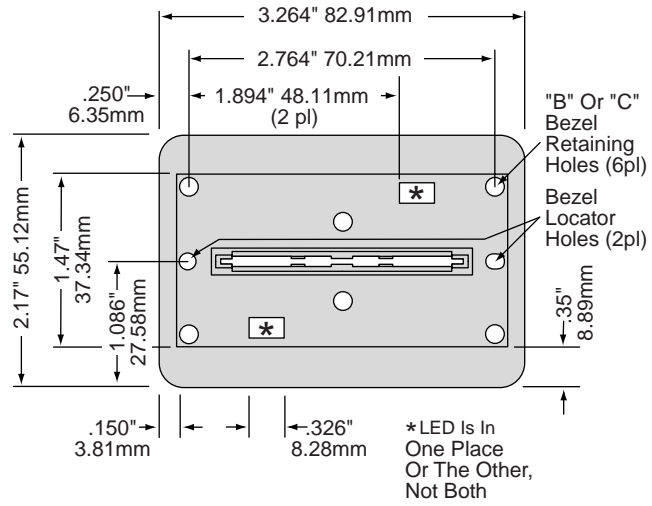

**Figure B-1. Bezel "A" Dimensions**

