



Output Formats

- Clock & data
- Wiegand 26 bit
- Wiegand 36 bit
- Wiegand 50 bit
- Other output formats available for most OEM applications

Features

- Single tri-colour LED normally red, green and yellow activated via external line
- Internal buzzer with external control line
- Stainless steel fixing plate with internal/external secure fixing
- Reliable read capability with head life in excess of 1 million passes
- Available either as Track 1, Track 2 or Track 3 ISO
- 2.5 metre (8.2ft) 8 core screened cable
- Dimensions: 112 x 42 x 36mm (4.40 x 1.65 x 1.41")
- Card speed is 125 to 380 cm per second (5 to 15" per second)
- Data range 325 to 12,250 bits per second
- All electronics are encapsulated in epoxy resin (except read head and buzzer aperture)
- Reads lo-co and hi-co magnetic-stripe cards
- Weatherproof -25°C to +65°C (-13°F to +150°F)
- CMOS Clock, Data and Card Present outputs (see technical data)
- Vandal-resistant

High specification Magstripe Reader

The AXM magstripe reader provides high-performance and reliability for any application; whether high-security access control, electronic point of sale, time and attendance or purely data acquisition. A wide variety of output formats are available to provide flexibility for most OEM applications.

The AXM magstripe reader is available with ABS housing and with fixings manufactured entirely from high-grade 316 cast stainless steel, or ultra-tough UV-resistant polycarbonate. Being made from such hard wearing materials not only means that the products are very durable, but also ensures that even in the harshest conditions the readers continue to operate.

As all the electronics are embedded in epoxy resin these products are weather-proof and vandal-resistant – making them an ideal choice for both indoor and outdoor use. The reader heads provide an extremely reliable reading capability with over 1 million head passes.

The single tri-colour LED provides a visual indicator-showing the current reader status, whilst the internal buzzer provides an audible indicator. Both indicators are utilised via external lines.

AXM-ABS

- Hardwearing, UV-resistant polycarbonate housing

Technical Data

Standard Clock and Data Output

This diagram represents active 'Low' CMOS clock, data and card present. On the data line, the 'high' level indicates a data '0' bit and the 'Low' level denotes a data '1' bit. Data must be accepted at the falling edge of the Clock pulse. The timings shown are for guidance purposes only and will in practice vary in accordance with the card speed.

Cable Connections

Reader supplied with 2.5 metre (8.2ft) - 8 core screened cable

Red	+VDC Supply
Blue	Card Present
Green	Clock (or Wiegand Data 0)
Yellow	Buzzer Control Line
White	Data (or Wiegand 1)
Black	0VDC Signal Ground
Violet	not in use
Orange	Green/Yellow LED Control Line

Reader Supply Voltage

+5VDC to +18VDC—recommended +12VDC

Cable Distance / Gauge

Maximum of 100 metres—24AWG (7/0.20)

LED and Buzzer Control Inputs

0 to +5VDC maximum.

Current Consumption

50mA at +5VDC and 20mA at +12VDC

Ordering Information

AXM-ABS 105-233-xxx-y

Where xxx signifies colour finish and y signifies output type.

Standard clock & data part number 105-231-SS-1

Finish: ABS—Polycarbonate

Output Types: 2—Clock & Data
3—Wiegand 26 bit
4—Wiegand 36 bit
5—Wiegand 50 bit

Track 2 standard— also available as Track 1 or Track 3

Standard Clock and Data Output—Signal Format

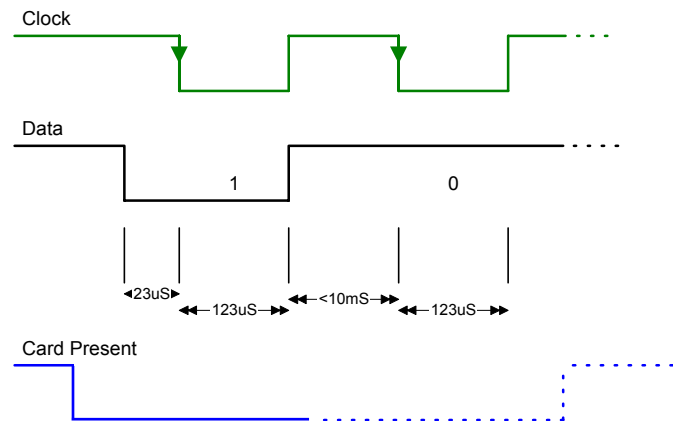

Wiegand Output—Signal Format

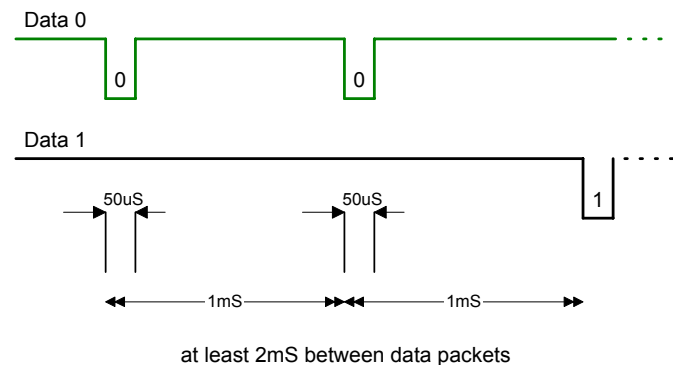

Warranty

For warranty details see terms and conditions.

CardPOS

EUROPE

CardPOS Europe
Unit 25-26
Shrivenham Hundred Business Park
Watchfield, Swindon
Wiltshire, SN6 8TZ (UK)

Tel: +44 (0)1793 780773
Fax: +44 (0)1793 786076
sales@cardpos.co.uk
<http://www.cardpos.co.uk>